

## Bronco 1/3 Roof Rack



### CAUTION BEFORE INSTALLING

**Before installation** - Read and understand all instructions, warnings, cautions, and notes contained in this installation instruction guide. Consult your vehicle owner's manual for proper disconnection of electrical and lifting of vehicle if required for installation of this product.

This install may require some technical skills and knowledge of basic mechanical work. If you do not feel that you are capable of performing this install please take this product to a trained professional.

After reading this guide please contact us with any questions or concerns before installing product.  
E-mail: [tech@calliert4x4.com](mailto:tech@calliert4x4.com)

**CALLIERT is not responsible for any bodily injury or harm to you or your vehicle as a result of an improper install.**









Proper installation of this kit requires knowledge of the factory recommended procedures for removal and installation of original equipment components. We recommend that the factory shop manual and any special tools needed to service your vehicle be on hand during the installation. Installation of this kit without proper knowledge of the factory recommended procedures may affect the performance of these components and the safety of the vehicle.

- **Always wear eye protection when operating power tools.**

*Inspect all contents of this package to make sure product is not damaged and all installation hardware has been included. If parts are missing from kit, please be prepared to provide the following information:*

- Name of purchase location
- Bar Code on side of box

# INSTALLATION MANUAL

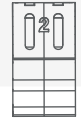
- ①  x1
- ②  x2
- ③  x4
- ④  x1
- ⑤  x2  x2
- ⑥  x2  x2
- ⑦  x2  x2

**a.**  x16  
M8 Washer

**b.**  x4  
M6 Washer

**c.**  x4  
M6x12 Round Head Hex Socket Bolt

**d.**  x4  
M8x20 mm button head socket cap screw

**e.**  x4  
M6 20x13x5 Square Nut

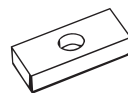
**f.**  x4  
25x20x5 mm M8 threaded rectangular nut

**g.**  x4  
M8x30 Cylindrical Head Hex Socket Bolt

**h.**  x8  
M8x45 Cylindrical Head Hex Socket Bolt

**i.**  x4  
M6 Lock Nut

**j.**  x16  
M8 Lock Washer

**k.**  x4  
58x18x4.5 mm Spacer

**l.**  x4  
55x18x3 mm Custom Nut

**m.**  x4  
M6x30 Cylindrical Head Hex Socket Bolt

**n.**  x1  
5mm hex key (or 5mm Allen key)

**o.**  x1  
6mm hex key (or 6mm Allen key)

**p.**  x1  
10mm socket wrench

# INSTALLATION MANUAL

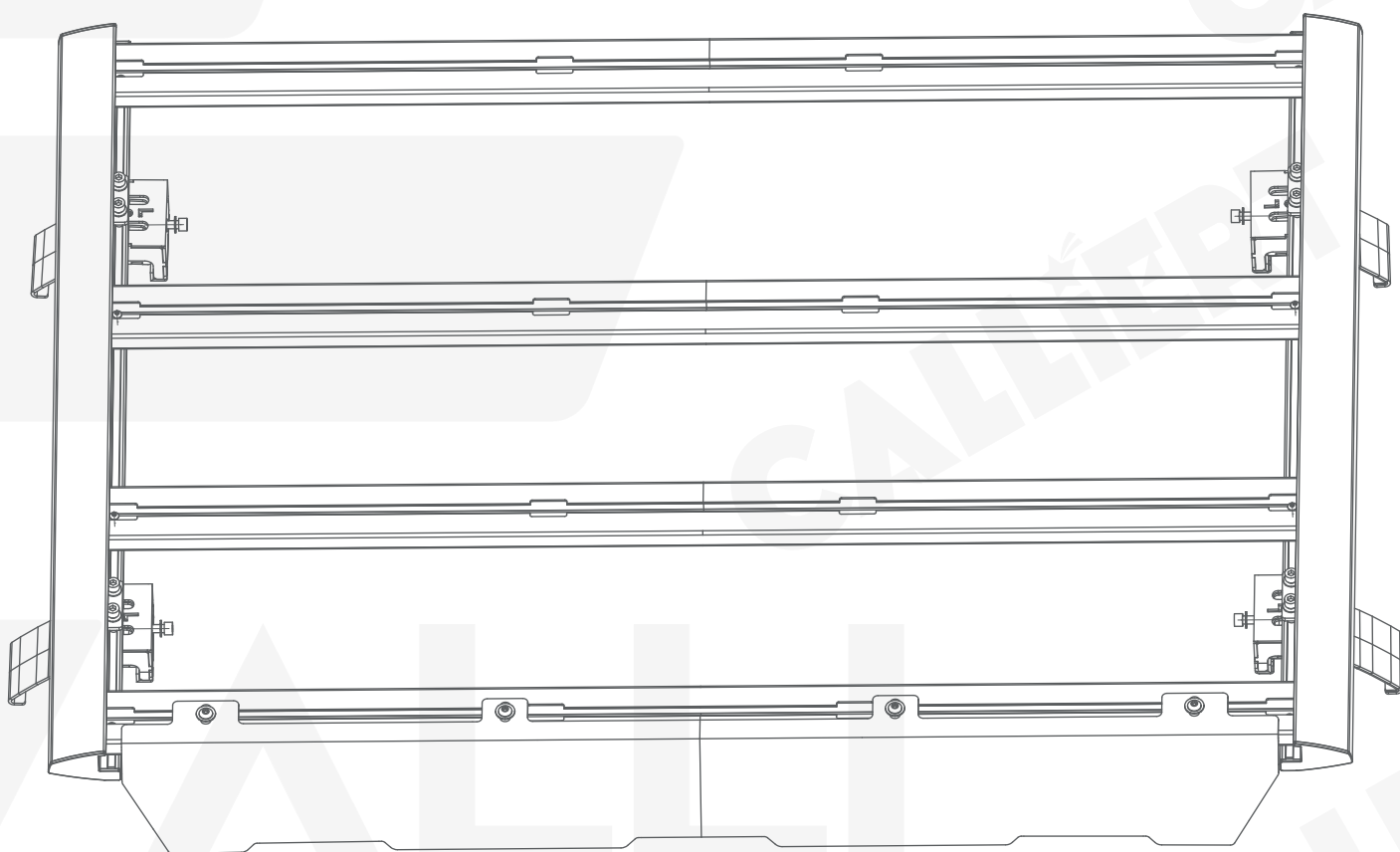

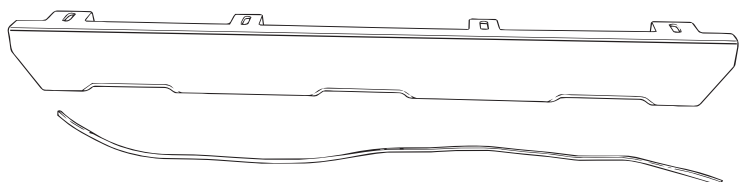

Prepare the required parts: ① and ④.

## 1

As shown in the figure, install part ④ onto part ①, and trim off the excess leather strap.

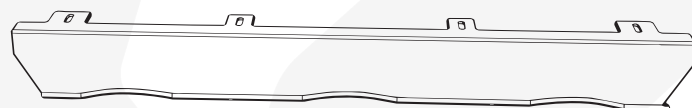

## 2

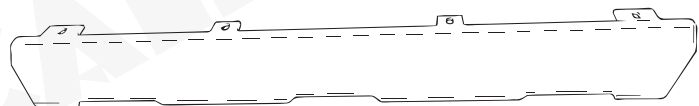

Prepare the required parts: a, d, f, j.

## 3



# 2

# INSTALLATION MANUAL

As shown in the figure, use a, d, and j to connect ① and f at the hole positions. (Note: Leave clearance for the slide rail.)

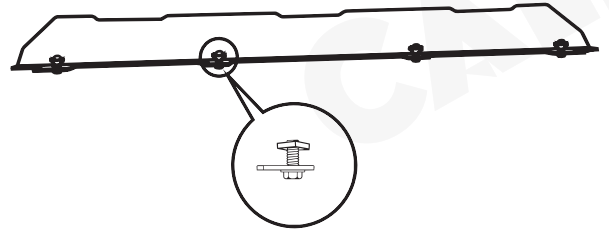

4

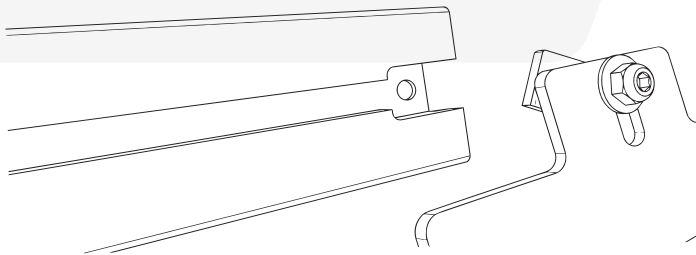

As shown in the figure, slide the assembled part ① into the track of part ③. (Note: Do not tighten the screws)

5

Prepare the required parts: ②, ⑤, and e.

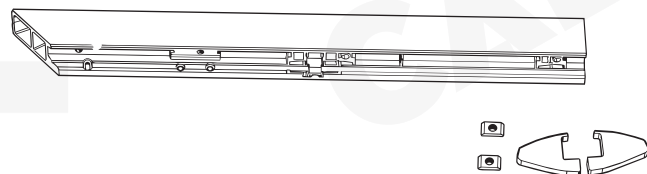

6



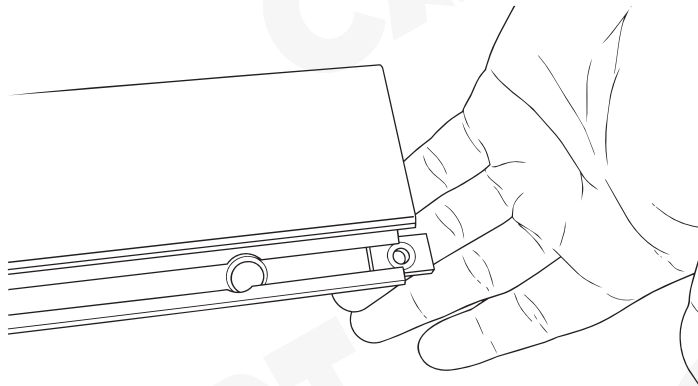

7

As shown in the figure, slide e into the track of part ②.

As shown in the figure, slide two e's into the track of each part ②.



8

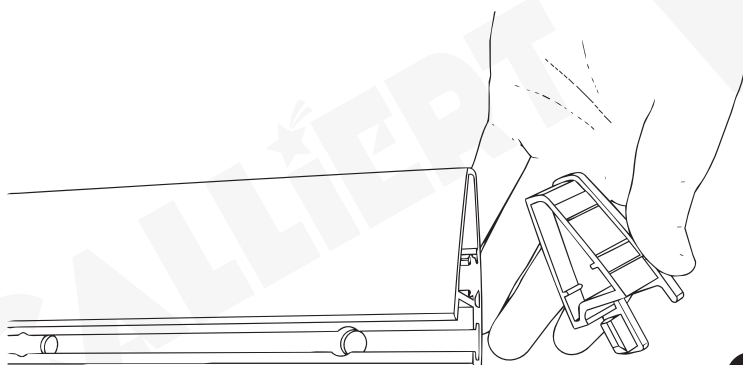

9

As shown in the figure, insert part ⑤ into the top and bottom ends of part ②.

# 4

# INSTALLATION MANUAL

As shown in the figure, install the crossbar of the spoiler at the front.

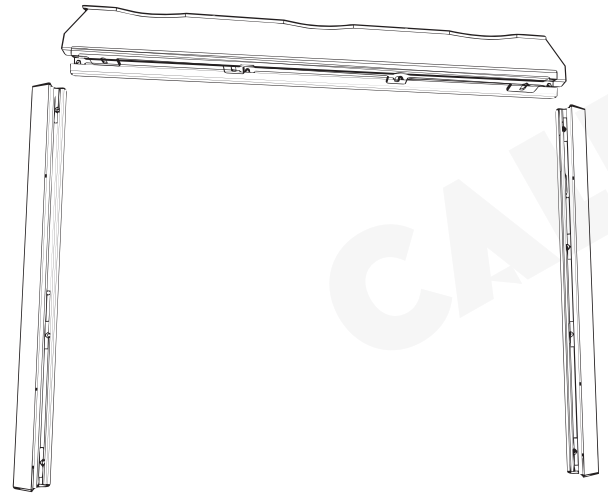

10

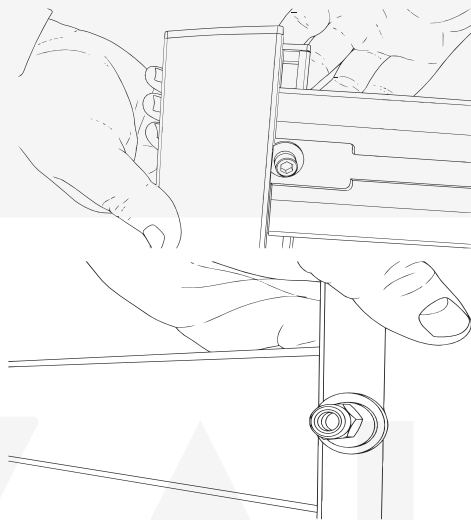

11

As shown in the figure, use b,m and i to connect part ② and part ③.

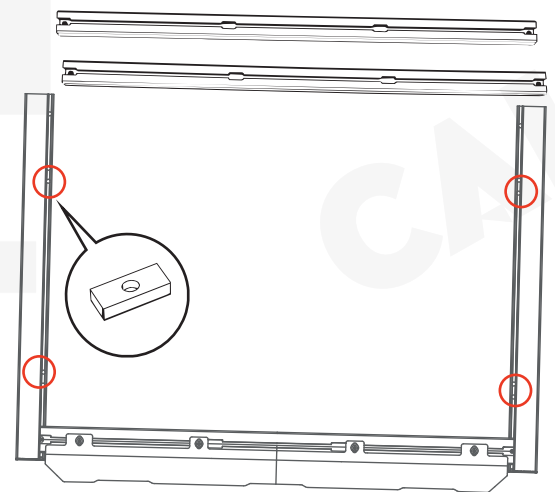

As shown in the figure, adjust the position of e to avoid the hole positions marked in the red circle.

12



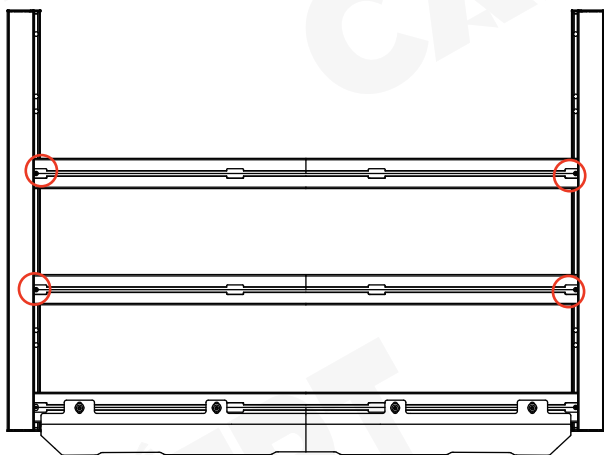

**13**

As shown in the figure, use c and e to connect part ② and part ③ at the hole positions indicated by the red circles on the crossbar.

As shown in the figure, use m and i to connect part ② and part ③. (Installation method is the same as step 11.)

**14**

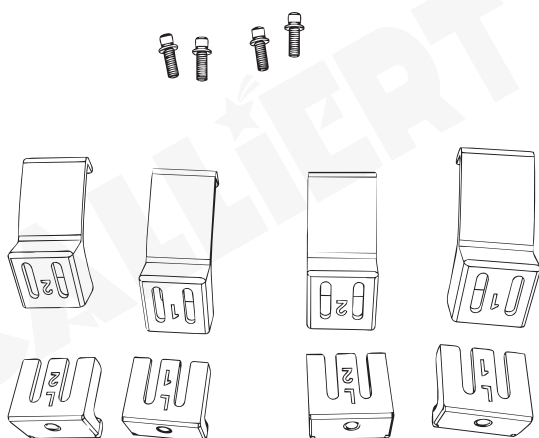
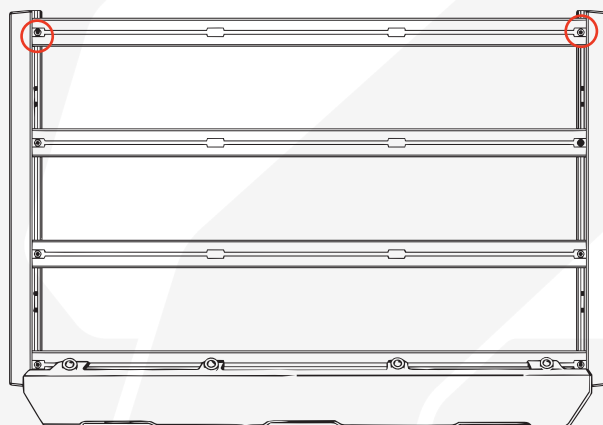

**15**

Prepare the required parts: ⑥, ⑦, a, g, and j.

# 6 INSTALLATION MANUAL

As shown in the figure, use a, g, and j to connect part ⑥ and part ⑦.

(Note: 1 and L1, 2 and L2 correspond to each other, Do not tighten the screws.)

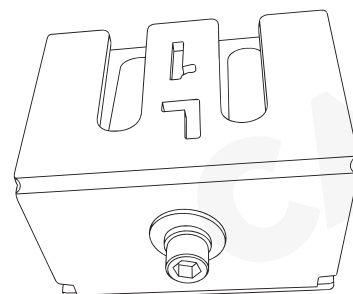

16

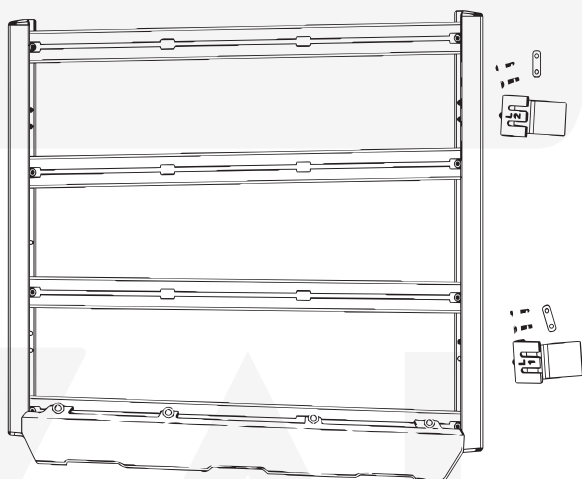

17

Prepare the required parts: a, h, j, k, l (these screws are already pre-assembled together. L1 is the front bracket, and L2 is the rear bracket.)

As shown in the figure, place l into the bottom notch of part ⑦.

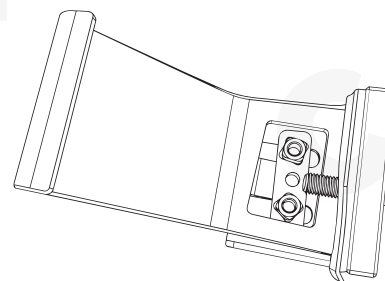

18



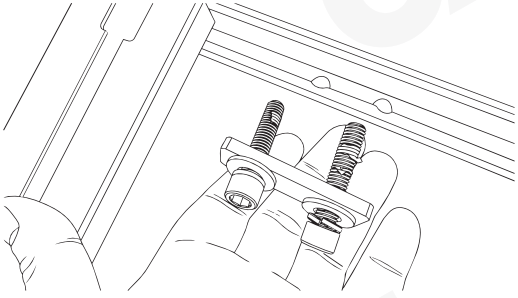

As shown in the figure, use a, h, j, k, and l to connect part ② and part ⑦ at the hole positions.

**19**

As shown in the figure, L1 is the front bracket, and L2 is the rear bracket. (Do not tighten the screws).

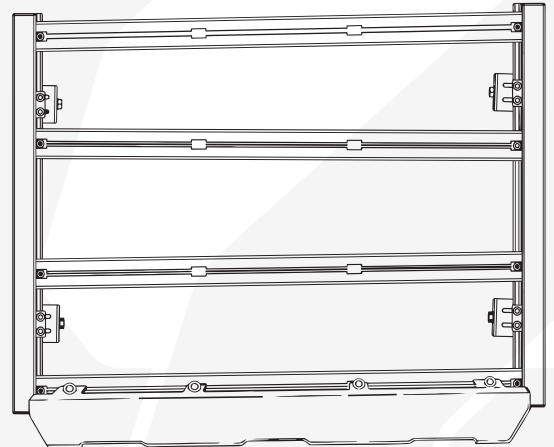

**20**

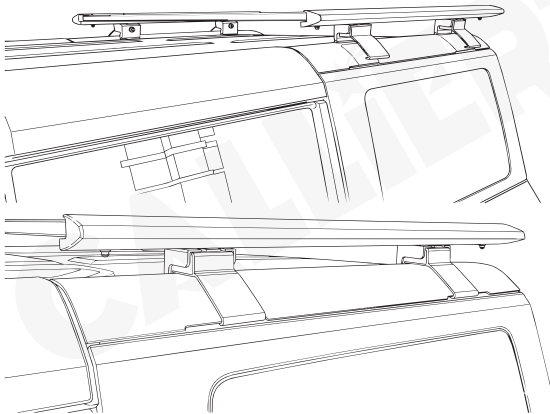

As shown in the figure, lift the luggage rack to the rear end of the roof, and snap part ⑦ into the corresponding hole positions on the roof.

**21**

# 8

# INSTALLATION MANUAL

As shown in the figure, tighten all the loose screws on the bracket. (Note: Tighten the screws in order — first tighten the screws at the yellow circle, then tighten the screws at the red circle).

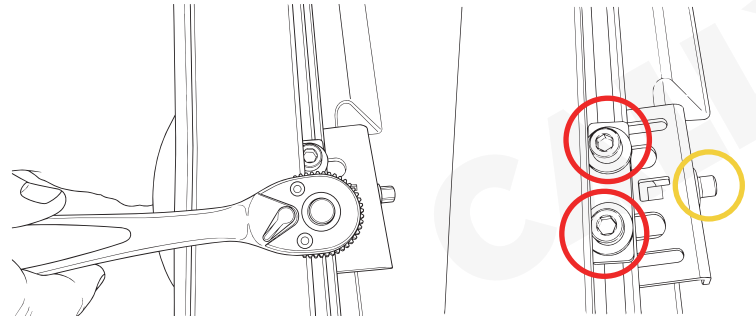

## 22

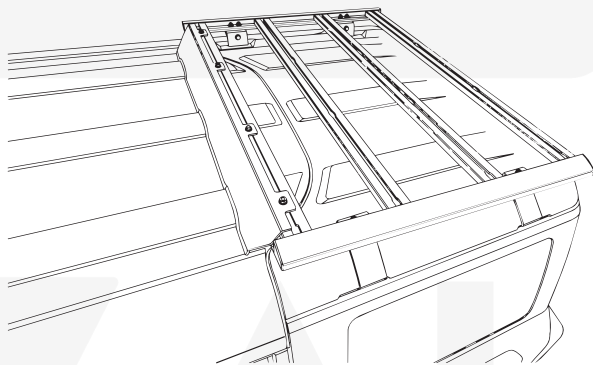

As shown in the figure, adjust the position of the spoiler so that it fits snugly against the roof, then tighten the screws to secure the spoiler.

## 23

Installation complete.

