

Operator's Manual

Save This Manual Keep this manual and read through the entire instructions before proceeding with installation. The product parts in this instruction may differ slightly from the actual product contents but generally does not affect the installation of the product. If you are not confident with your mechanical skills, please ask for the help of a professional to install this accessory.

CALLIERT

JEEP WRANGLER (JK) FENDER FLARES

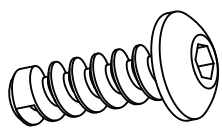
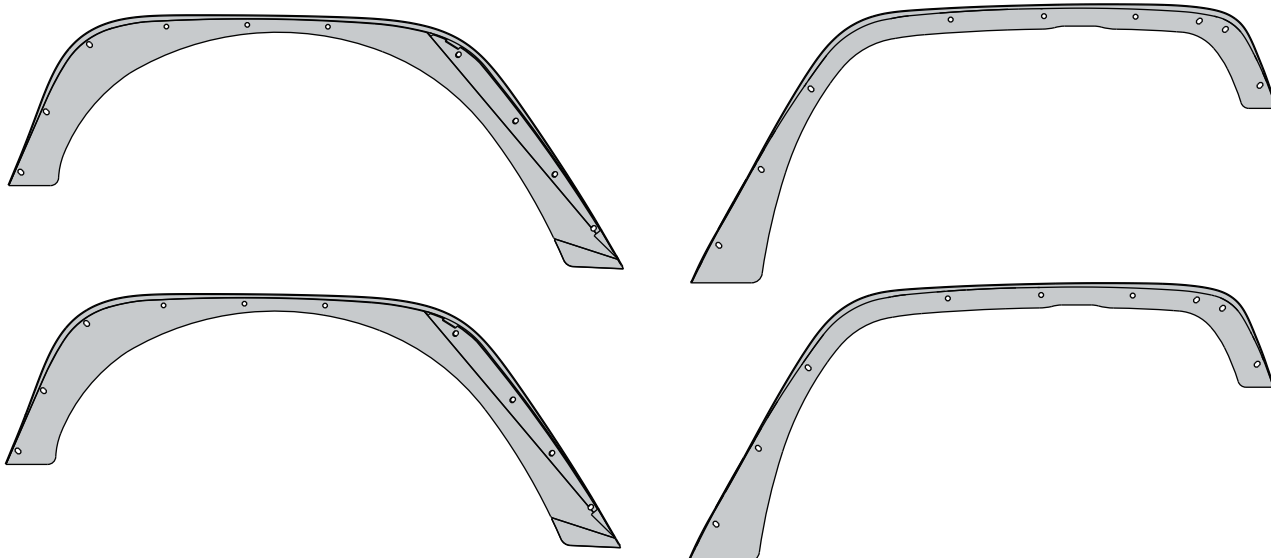

×38

M6X20 Allen Head Bolt

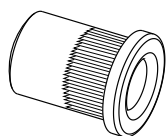

×38

M6 Rivet Nut

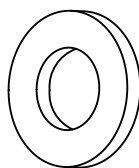

×38

M6x12 Flat Washer

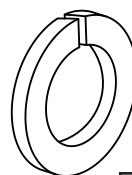

×38

M6 Lock Washer

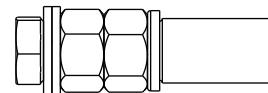

×1

Rivet Tool

Visit our website at: <https://www.aotowo4x4.com>

⚠ WARNING

Read the instructions all the way through before installing the fender flares.

When unpacking, make sure that the product is intact and undamaged. If any parts are missing or broken, please contact us: www.aotowo4x4.com.

No portion of this manual or any artwork contained here in may be reproduced in any shape or form without the express written consent. Diagrams within this manual may not be drawn proportionally. Due to continuing improvements, actual product may differ slightly from the product described herein. Tools required for assembly and service may not be included.

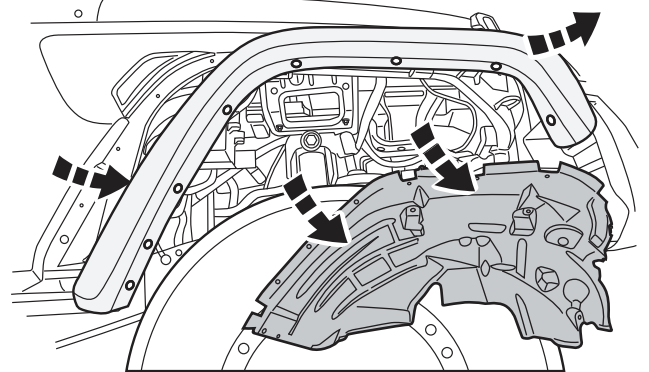
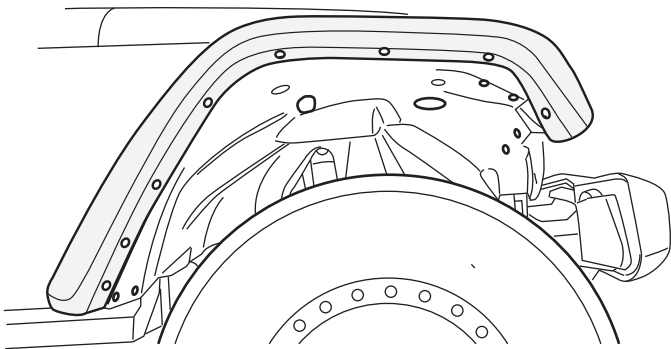

1. Remove the bolts that holding the inner liner on.
2. Grab the inner liner fender pull it out and remove the front fender flare.

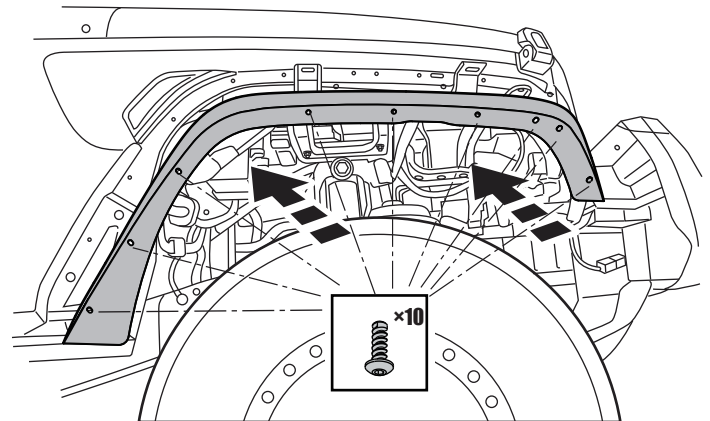
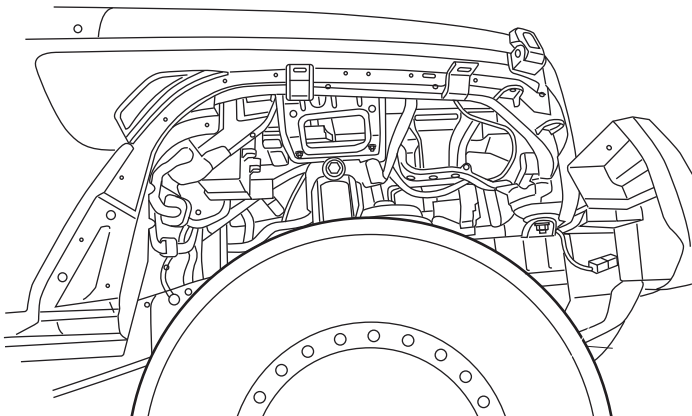

3. Hold new fender flare onto the fender panel and use the rivet nut tool to tighten the rivet nuts.

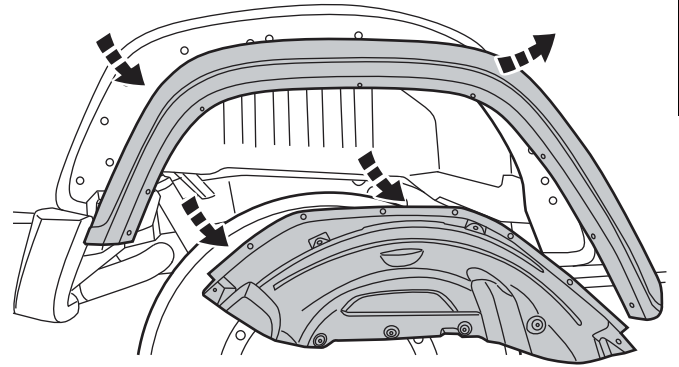
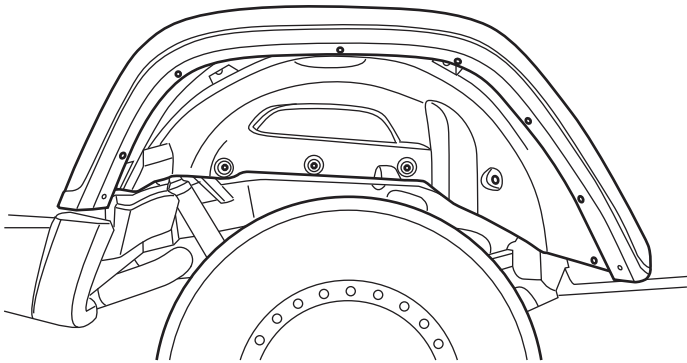

1. Use the panel tool to remove the fasteners from the rear inner fender liner.
2. Grab the inner liner fender pull it out and remove the rear fender flare.

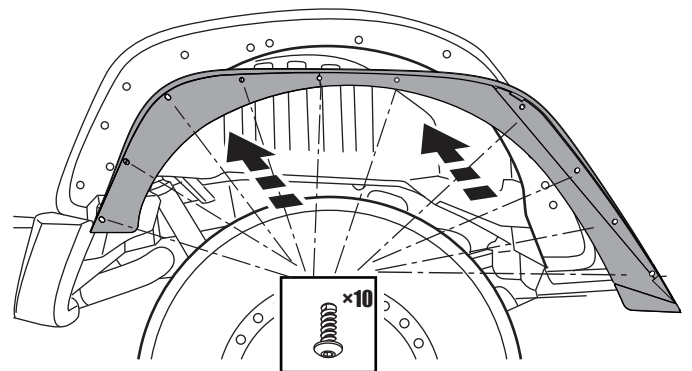
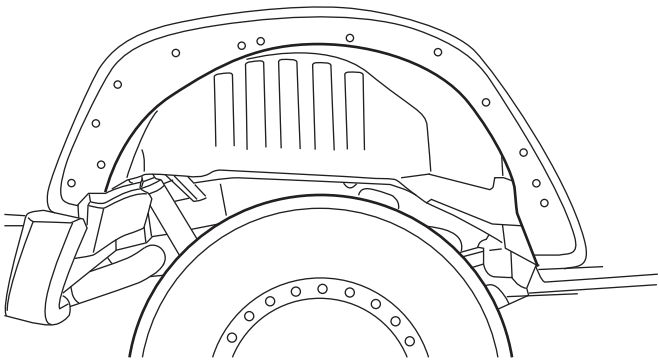

3. Hold new fender flare onto the fender panel and use the rivet nut tool to tighten the rivet nuts.